



8 POINT  
MICRO-  
ADJUSTMENT

# BT8390-VESA400MAF SYSTEM X™ UNIVERSAL INTERFACE ARMS WITH MICRO-ADJUSTMENT FOR MEDIUM / LARGE SCREENS



Ideal for assembling video walls and other multi-screen applications, these interface arms are designed to mount medium to large sized screens on to System X horizontal mounting rails. The universal design is compatible with all video wall screens and the modular design allows an almost endless number of configurations to be assembled, in both landscape or portrait orientations. Tool-less 8 point micro-adjustment allows perfect alignment of displays and a mounted depth of 114mm from the wall allows easy access for cables and connectors.

### SPECIFICATION

Recommended screen size	42" - 65"
Max load	50kg
VESA® & non-VESA fixings	up to 400mm* (vertical dimension)
Depth (typical wall mounted install)	114mm
Colour	Black

Supplied in pairs

\*The VESA specification of the BT8390-VESA400MAF refers to the vertical dimension only. All System X interface arms can be positioned as far along the rail as necessary.

### FEATURES

- Part of the System X range for use in a variety of applications
- Ideal for video walls and other multi-screen installations
- Universal design compatible with most screens
- Suitable for landscape or portrait mounting
- High-end aesthetic quality
- Tool-less 8 point micro-adjustment for seamless display alignment
- Lateral adjustment - position arms anywhere along the length of the rail
- Safety screws help prevent unauthorised removal of screens
- Simple 'hook-on' installation
- All mounting hardware included



Tool-less 8 point micro-adjustment for seamless display alignment



Safety screws help prevent unauthorised removal of screens

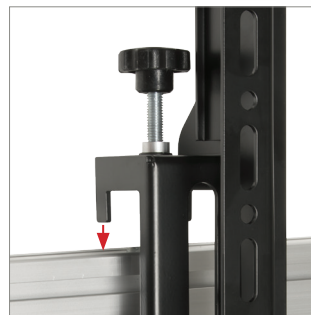

Simple 'hook-on' installation



Suitable for landscape or portrait mounting

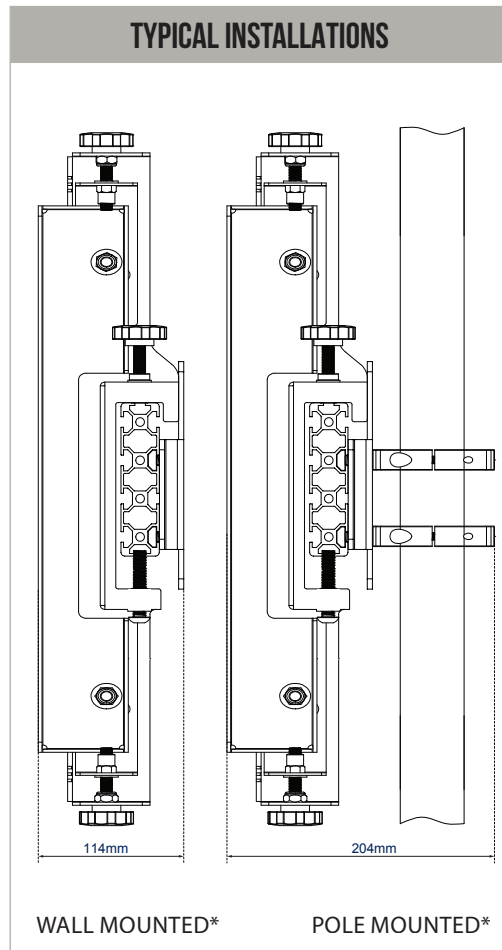
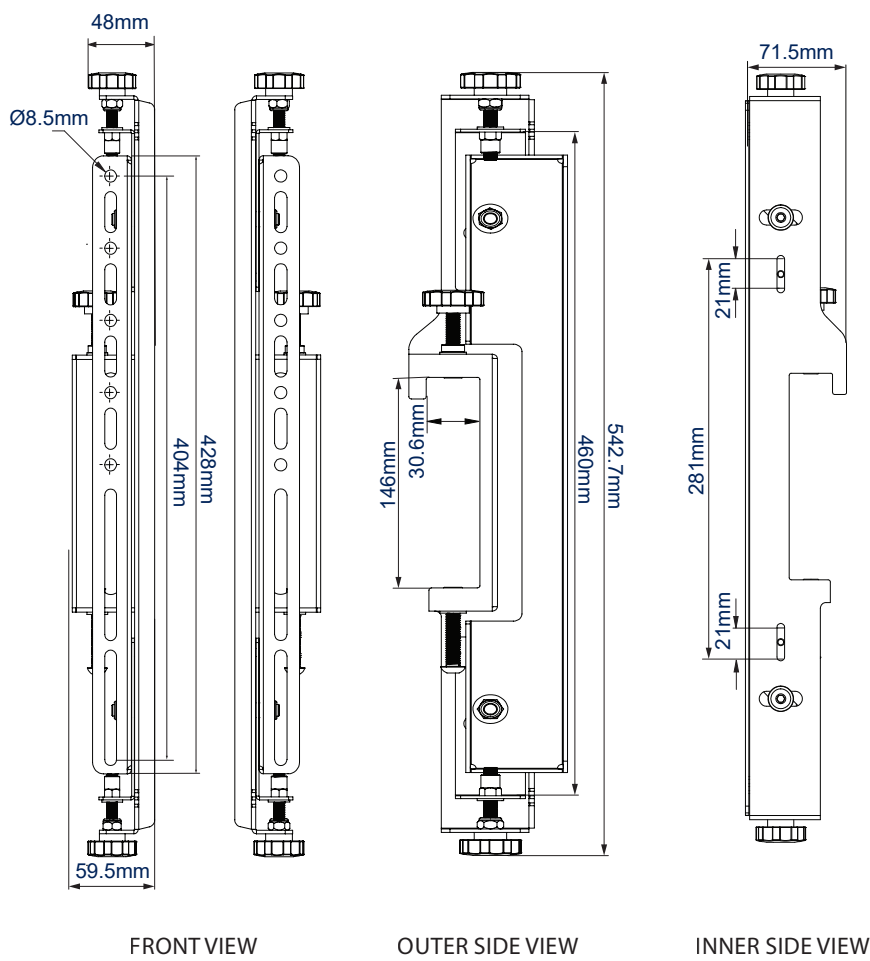

\* Please note all other components shown in the technical drawings are available separately.

**PACKING INFORMATION**

COLOUR:	ORDER REF:	EAN CODE:	MASTER CARTON QTY:	INNER CARTON QTY:	MASTER CARTON WEIGHT:	MASTER CARTON CUBE:
Black	BT8390-VESA400MAF/B	5019318501197	6	0	23.5kg	0.064cbm

**ACCESSORIES AND RELATED PRODUCTS**



**Interface Adaptor Arms for VESA 600 x 400** can be used with VESA 200 or 400 arms to increase the maximum vertical fixings to 600mm for larger screens



**Mounting Rails** can be fixed to columns, walls or poles using System X components



**Extension Kits** combine mounting rails together to create longer installations



**Pop-In, Pop-Out Interface Arms** allow access to the rear of screens for easy servicing and maintenance

© 2015 B-Tech Av Mounts Professional Design & Manufacturing Ltd. All rights reserved. The information in this specification sheet reflects the current technical specifications at the time of print. We reserve the right to change the technical or physical specifications without notice. B-Tech Av Mounts Professional Design & Manufacturing Ltd. B-Tech Av Mounts Professional Design & Manufacturing Ltd. is not responsible for loss or damage caused by improper installation, use, or modification of the product. Any reproduction or transmission of any part of this specification is expressly prohibited, unless prior written permission has been granted by B-Tech Av Mounts Professional Design & Manufacturing Ltd. (B-Tech Av Mounts Professional Design & Manufacturing Ltd.)  
 SS-V1.1-BT8390-VESA400MAF-280317 European Trademark No.: 002741256-0026